

PAD AREA  
 KEEP OUT AREA  
 NO COPPER AREA  
 (NO Trace&Via&GND)

- NOTES :
- MATERIAL :
    - HOUSING:LCP S475 UL94 V-0, BLACK COLOR.
    - SHELL: STAINLESS STEEL SUS304
    - CONTACT: COPPER ALLOY C5210
  - FINISH :
    - CONTACT: GOLD PLATING ON CONTACT AREA, GOLD FLASH ON SOLDERTAIL AREA. 50u" MIN NICKEL PLATING OVERALL.
    - SHELL: 30u" MIN SOLDERABLE NICKEL PLATING OVERALL. GOLD FLASH ON SOLDERTAIL AREA.
  - ELECTRICAL CHARACTERISTICS:
    - OPERATING VOLTAGE : 100V AC(rms)/DC.
    - CURRENT RATING : 0.5 A.
    - OPERATING TEMPERATURE: -25°C~+85°C.
    - CONTACT RESISTANCE: 100 m OHMS MAX.
    - INSULATION RESISTANCE: 1000M OHMS MIN. AT 250VDC.
    - DIELECTRIC WITHSTANDING VOLTAGE:500 VAC/1MINUTE.

- PART.NO.: MR265-AP401-\*\*
- 08: 功能区镀金1U", 锡脚Gold Flash  
 09: 功能区镀金3U", 锡脚Gold Flash  
 10: 功能区镀金5U", 锡脚Gold Flash  
 11: 功能区镀金15U", 锡脚Gold Flash  
 12: 功能区镀金30U", 锡脚Gold Flash

RECOMMEENDER PCB LAYOUT  
TOLERANCE UNLESS OTHERWISE IS ±0.05

COMPOSITION OF DETECTION	
CARD DETECT(SW)	
CD	COMM
CARD DETECTION/SWITCH	
CARD INSTALLATION:ON	
NON CARD:OFF	

Pin	Define
#1	DAT2
#2	CD/DAT3
#3	CMD
#4	VDD
#5	CLK
#6	VSS
#7	DAT0
#8	DAT1

GENERAL	TOLERANCE	DWG.NO.	MR265-AP401-00	PART.NO.	MR265-AP401-**	DRAWN	L.M.J 2021.08.06
x.±0.50	x.*± 5°	REV.	A	TITLE	Micro SD Push H1.35-2 conn	CHECKED	
.x±0.25	.x*± 2°	SIZE		SHEET	1/2	APPROVED	
.xx±0.15	.xx± 1°	A4					

东莞市欧联电子科技有限公司  
 DONGGUAN OLN ELECTRONICS TECHNOLOGY CO., LTD.

# 东莞市欧联电子科技有限公司

## 包装作业规范

### 包装作业图示及说明 (PACKING OPERATION DIAGRAM & INSTRUCTION)

- 一.
- 1) 将成品一一放入REEL包装盘内, 依同一方向放入.
  - 2) 包装时, 如下图所示, 放置 2000 个成品.

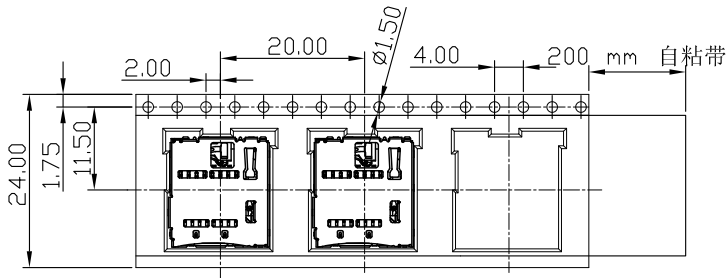

- 二.
- 1) 装盘前先把前面空15pcs产品, 然后再开始装盘, 尾端也需空出15pcs产品, 上带加长200mm.
  - 2) 装满成品的REEL包装盘如下图所示.

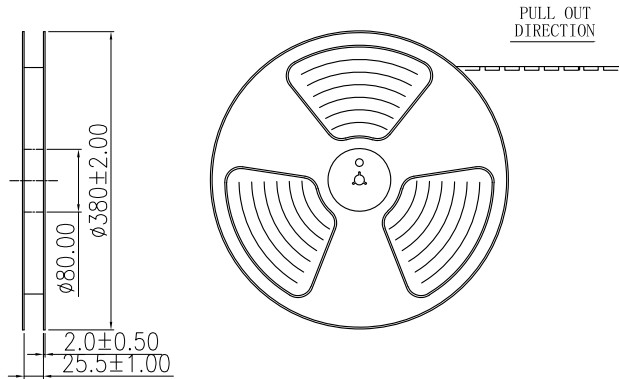

- 三.
- 1) 每箱装 10 盘REEL包装盘.
  - 2) 每箱放置20000PCS 的成品.

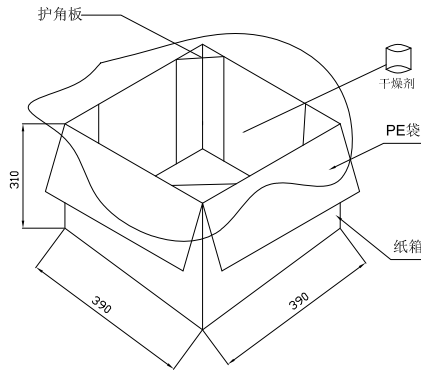
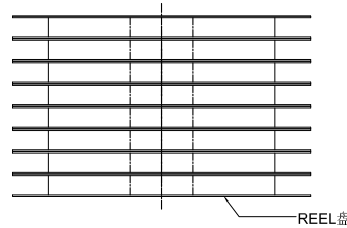

- 四.
- 1) 用TAPE将纸箱封实.

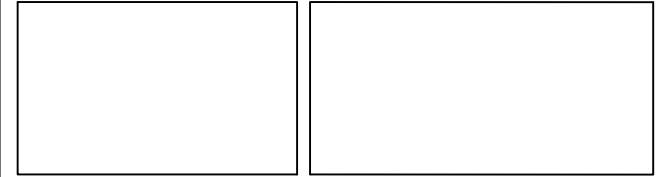

### 備註 (REMARK)

1. 若有未裝滿之零數箱, 必須以緩衝材塞滿.

GENERAL TOLERANCE	TOLERANCE	DWG.NO.	MR265-AP401-00	PART.NO.	MR265-AP401-**	DRAWN	L.M.J 2021.08.06
x.±0.50	x.°± 5°	REV.	A	TITLE	Micro SD Push H1.35-2 conn	CHECKED	
.x±0.25	.x°± 2°	SIZE		SHEET	2/2	APPROVED	
.xx±0.15	.xx°± 1°	A4					



东莞市欧联电子科技有限公司  
DONGGUAN OLN ELECTRONICS TECHNOLOGY CO., LTD.